

Matrox Radiant eCL >>>

High-performance Camera Link® frame grabber with FPGA-based processing offload.



Benefits

Offload and accelerate image processing to free and assist the host CPU using an Altera® Stratix® III / IV¹ FPGA

Optimize multi-camera applications via support for up to four independent Base (eCL-QB) or up to two Full (eCL-DF) Camera Link® cameras per board

Perform deterministic image acquisition by way of the jitter-free Camera Link® interface

Eiminate lost pixels through a x8 PCIe® host interface and ample on-board buffering

Use the highest-rate cameras with available support for 10-taps (eCL-F) at 85 MHz

Reduce cabling and eliminate power supplies by way of Power over Camera Link® (PoCL) support

Reduce development and validation costs through a managed lifecycle offering consistent long term availability

Implement image capture with ease and confidence using Matrox Imaging Library (MIL) application development toolkit

Maintain flexibility and choice by way of 32-bit and 64-bit Windows® XP / Vista® / 7 and Linux support

Utmost performance for a Camera Link® frame grabber

The Matrox Radiant eCL frame grabber matches the highest level of performance offered by the Camera Link® interface standard with support for the maximum transmission rate beyond the maximum number of ports. The acquisition of such massive amounts of data is usually accompanied by image processing operations that can overwhelm the most capable computer. To address this imbalance, the Matrox Radiant eCL features an on-board real-time processing FPGA device that can be configured to offload and even accelerate the most compute intensive part of typical image processing applications without generating additional data traffic within the host computer.

Offload and accelerate repetitive tasks from the host CPU

As image size continues to grow, frame rate steadily increases and applications are expected to do more, the demands for processing on the host system are escalating. Alleviating this pressure, the Matrox Radiant eCL can offload repetitive CPU intensive tasks on the Altera® Stratix® III / IV¹ FPGA such as spatial and temporal filtering, gain and offset correction, dead pixel correction, optical and perspective distortion correction, Bayer color interpolation, color space conversions and frequency domain transformations, freeing valuable processing resources for the rest of the application and accelerating the application. The operations performed on-board are controlled through the Matrox Imaging Library (MIL) application development software. Through MIL, a FPGA configuration can be rearranged to perform a required sequence of operations without having to necessarily generate a new FPGA configuration. When the need arises, Matrox's FPGA design services can be employed to generate an application-specific FPGA configuration.

Matrox Radient eCL

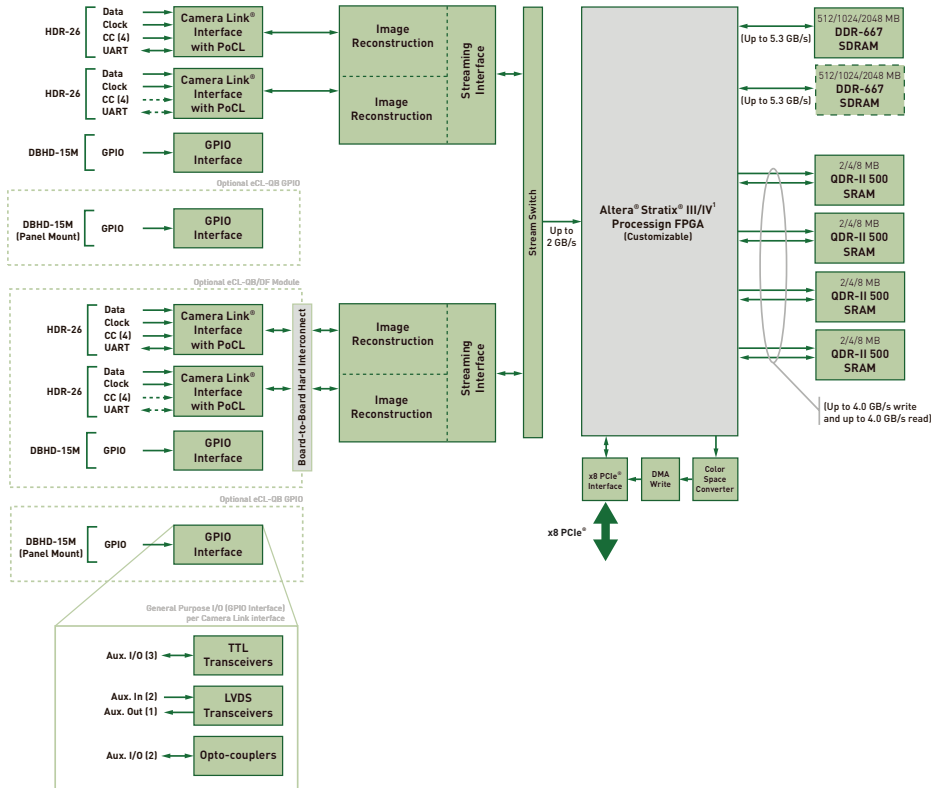

Versatile Camera Link® Interface

For low-latency and deterministic acquisition, Camera Link® provides a scalable and proven solution for machine vision applications. From cost-sensitive low data rate applications, to mainstream applications including color and right up to maximum bandwidth applications, Camera Link® is an excellent fit. The introduction of the mini Camera Link® connector (HDR) has led to higher density multi-camera systems by enabling two Base or one Full mode Camera Link® interface with triggering and general purpose I/O in a single slot.

The Matrox Radient eCL-QB is capable of simultaneously capturing from up to four completely independent Base Camera Link® cameras at up to 85 MHz. Fully supporting Power over Camera Link® (PoCL), the Matrox Radient eCL-(Q)B can reduce cabling complexity and eliminate the need for bulky and costly external camera power supplies. Alternatively the Matrox Radient eCL-DF, supporting up to two Medium/Full cameras with up to 10-taps at up to 85 MHz, can acquire and reconstruct images from the most advanced multi-tap high-performance area and line scan cameras.

High-performance host interface

A x8 PCIe® host interface provides the throughput necessary to ensure the continuous flow of pixels from the Matrox Radient

eCL to host memory. With a peak bandwidth of up to 2 GB/s, the Matrox Radient eCL's host interface prevents pixels from inadvertently being discarded while the point-to-point connectivity of PCIe® stops other add-in devices from taking away valuable bandwidth between the frame grabber and the host PC.

Matrox Radient eCL



Lifecycle managed for consistent long term supply

Matrox Imaging not only carefully selected each component in the Matrox Radiant eCL to ensure product availability in excess of five years, but also exercises strict change control to provide consistent supply. Longevity of stable supply lets OEMs achieve maximum return on the original investment without incurring the additional costs associated with the repeated validation due to constantly-changing products.

Field-proven application development software

Matrox Radiant eCL is supported by the Matrox Imaging Library (MIL), a comprehensive collection of software tools for developing industrial imaging applications. MIL features interactive software and programming functions for image capture, processing, analysis, annotation, display and archiving. These tools are designed to enhance productivity, thereby reducing the time and effort required to bring your solution to market. Refer to the MIL datasheet for more information.

Included with MIL are ready-made configurations for the FPGA-based processing core that implement a variety of image processing functions. Custom configurations can also be created on demand and upon evaluation.

Specifications

Hardware

- x8 PCIe® host bus interface
 - half-length, full-height
- Altera® Stratix® III / IV¹ processing FPGA

Logic Rich Devices	Equivalent Logic Elements	Max. 18-bit x 18-bit Multipliers
EP3SL110	107,5K	288
EP3SL150	142,5K	384
EP3SL200	200K	576
EP3SL340	337,5K	576
DSP Rich Devices		
EP3SE80	80K	672
EP3SE110	107,5K	896
EP3SE260	255K	768
EP4SE360	353,6K	1040
EP4SE530	531,2K	1024
EP4SE820	813K	960

- 1/2/4 GB of DDR2-667 SDRAM
 - up to 10.6 GB/s read and write
- 8/16/32 MB of QDR-II 250 SRAM
 - up to 4 GB/s read and 4 GB/s write
- Camera Link® Acquisition
 - mini Camera Link® connectors (HDR-26)
 - 20 MHz to 85 MHz Camera Link® clock
 - one (1) serial port per Camera Link® ports
 - two (2) Base Camera Link® ports (eCL-B) or four (4) Camera Link® Base ports (eCL-QB)
 - Power over Camera Link® (PoCL) with SafePower
 - one (1) Medium/Full Camera Link® port (eCL-F) or two (2) Camera Link® Full ports (eCL-DF)
 - up to 10-tap support
- supports frame and line scan sources
- on-board image reconstruction
- on-board color space conversion
 - input formats
 - mono/Bayer 8-bit and 16-bit
 - BGR packed 24-bit and 48-bit
 - output formats
 - mono 8-bit and 16-bit
 - 24-bit BGR/RGB packed
 - 32/48-bit BGR_α/RGB_α
 - YUV 16-bit
 - YCrCb
- one (1) DBHD-15 male GPIO connector (two (2) for eCL-QB/DF)
 - three (3) TTL configurable auxiliary I/O's
 - two (2) LVDS auxiliary inputs
 - one (1) LVDS auxiliary output
 - two (2) opto-isolated auxiliary inputs
- optional add-on DBDHD-15 male GPIO connector (up to 2 for eCL-QB)
 - three (3) TTL configurable auxiliary I/O's
 - two (2) LVDS auxiliary inputs
 - one (1) LVDS auxiliary output
 - two (2) opto-isolated auxiliary inputs
- support for one (1) quadrature rotary encoder per Camera Link® port
- MIL license fingerprint and storage

Dimensions and environmental information

- Matrox Radient eCL
- 167.6 mm L x 111.1 mm H x 18.7 mm W (6.6" x 4.38" x 0.74")
- 1.0 A @ 3.3V, 3.05 mA @ 12V or 30.3 W typical power draw² with PoCL
- additional Camera Link[®] module (eCL-QB/DF)
- 45.0 mm L x 106.65 mm H x 18.7 mm W (1.77" x 4.20" x 0.74")
- 1.0 A @ 3.3V, 0.8 mA @ 12V or 13 W additional power draw with PoCL
- operating temperature: 0°C to 55° C (32° F to 131° F)
- relative humidity: up to 95% (non-condensing)
- FCC class A
- CE class A
- RoHS-compliant

Software Environment

- Matrox Imaging Library (MIL) drivers for 32/64-bit Microsoft[®] Windows[®] XP / Vista[®] / 7
- MIL drivers for 32/64-bit Linux

Ordering Information

Hardware

Part number	Description
RAD 2G DB 150400*	Matrox Radient eCL-DB dual-Base Camera Link [®] frame grabber with 2 GB DDR2-667 SDRAM, Altera [®] Stratix [®] III EP3SL150-C4 processing FPGA and no SRAM.
RAD 2G SF 150400*	Matrox Radient eCL-SF single-Medium/Full Camera Link [®] frame grabber with 2 GB DDR2-667 SDRAM, Altera [®] Stratix [®] III EP3SL150-C4 processing FPGA and no SRAM.
RAD 2G QB 150400*	Matrox Radient eCL-QB quad-Base Camera Link [®] frame grabber with 2 GB DDR2-667 SDRAM, Altera [®] Stratix [®] III EP3SL150-C4 processing FPGA and no SRAM.
RAD 2G DF 150400*	Matrox Radient eCL-DF dual-Medium/Full Camera Link [®] frame grabber with 2 GB DDR2-667 SDRAM, Altera [®] Stratix [®] III EP3SL150-C4 processing FPGA and no SRAM.
RAD 2G DB 150416*	Matrox Radient eCL-DB dual-Base Camera Link [®] frame grabber with 2 GB DDR2-667 SDRAM, Altera [®] Stratix [®] III EP3SL150-C4 processing FPGA and 16 MB SRAM. Ask for availability. Subject to minimum order quantity.
RAD 2G SF 150416*	Matrox Radient eCL-SF single-Medium/Full Camera Link [®] frame grabber with 2 GB DDR2-667 SDRAM, Altera [®] Stratix [®] III EP3SL150-C4 processing FPGA and 16 MB SRAM. Ask for availability. Subject to minimum order quantity.
RAD 2G QB 200432*	Matrox Radient eCL-B quad-Base Camera Link [®] frame grabber with 2 GB DDR2-667 SDRAM, Altera [®] Stratix [®] III EP3SL200-C4 processing FPGA and 32 MB SRAM. Ask for availability. Subject to minimum order quantity.
RAD 2G DF 200432*	Matrox Radient eCL-F dual-Medium/Full Camera Link [®] frame grabber with 2 GB DDR2-667 SDRAM, Altera [®] Stratix [®] III EP3SL200-C4 processing FPGA and 32 MB SRAM. Ask for availability. Subject to minimum order quantity.

Software

Call Matrox Imaging or your local sales representative for more information.

Note:

1. Availability subject to pending qualification.
2. Typical power consumption for RAD2GSF150416*.