

Matrox Morphis Evo >>



Multi-channel video capture / H.264 encoding board for digital video recording applications.



Key features

- x1 PCIe™ short card
- simultaneously capture from up to 16 independent CVBS video sources
- accepts NTSC, PAL, RS-170 and CCIR video feeds
- real-time multi-channel H.264 encoder
- 16 audio inputs¹
- 8 sensor inputs, 8 relay outputs
- RS-485/422 interface
- watchdog timer
- programmed using Matrox Imaging Library (MIL) sold separately
- supports 32-bit Microsoft® Windows® XP

Highly-integrated design

Matrox Morphis Evo is a cost-effective board for digital video recording (DVR) applications that require real-time capture and simultaneous compression of multiple standard video sources in full resolution and frame rate. Compression is performed using H.264, the new industry standard with improved image quality, while minimizing storage and network transmission requirements.

16 video inputs devised for surveillance

Matrox Morphis Evo allows for the simultaneous capture from up to 16 independent standard video sources. Each video input benefits from hardware-based motion, blind, night and scene change detection commonly required in security systems. Moreover, the Matrox Morphis Evo also enables simple graphics and text to be superimposed on the captured video. Selectable privacy regions can hide sensitive portions of the field of view.

Real-time multi-channel H.264 encoding with audio

Matrox Morphis Evo features a real-time multi-channel Baseline Profile (BP) H.264 encoder. H.264 is also known as MPEG-4 part 10, and was developed by the ITU-T Video Group Coding Experts group (VCEG) in conjunction with the ISO/IEC Moving Picture Expert Group (MPEG). This video compression standard provides an optimal compression ratio without compromising quality, and is ideal for the transmission of video over a medium with restricted bandwidth or for maximizing video storage. The real-time multi-channel H.264 encoder supports 16 full D1² video streams at once. Parameters such as frame rate, resolution, or bit rate can be changed on-the-fly and on a per channel basis without stopping and restarting the encoding. Up to 16 mono audio inputs can also be encoded with the video with a sampling rate of 8KHz or 16KHz in G.711 A-law compression format.

Accessory functionality

In addition to the core video capture and compression functionality, Matrox Morphis Evo incorporates a variety of features to simplify overall integration. These features include auxiliary I/Os that eliminate the need for a third-party I/O board and a RS-485/422 serial port to control cameras with motorized pan, tilt and zoom (PTZ). Also included is an analog spot monitor output to view video inputs individually.



» Matrox Morphis Evo

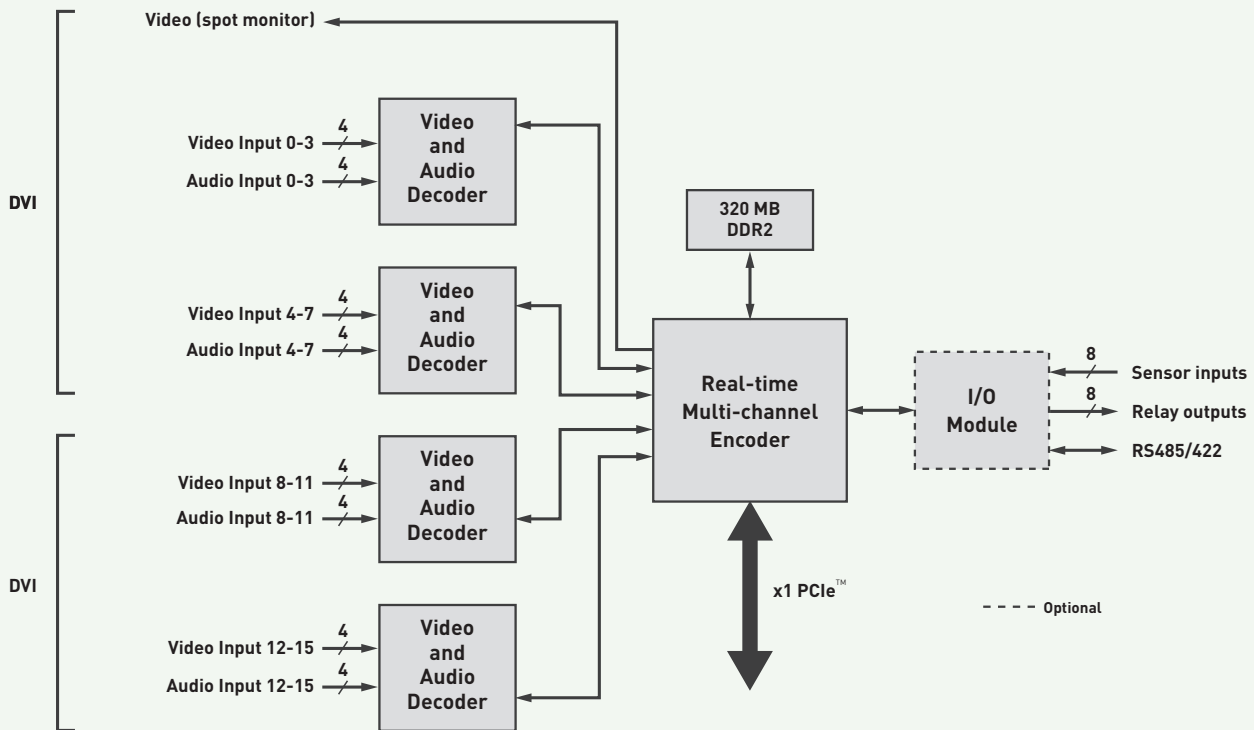

Field-proven application development software

Matrox Morphis Evo is supported by the Matrox Imaging Library (MIL), a comprehensive collection of software tools for developing industrial imaging applications. MIL features interactive software and programming functions for image capture, processing, analysis, annotation, display and archiving. The playback of H.264 A/V streams is performed through third-party video players. These tools are designed to enhance productivity, thereby reducing the time and effort required to bring your solution to market. Refer to the MIL datasheet for more information.

» Third-party A/V playback



H.264 playback is performed through third-party video players.

Specifications

Video capture

- analog composite (CVBS) NTSC/PAL/RS-170/CCIR
- connect and simultaneously capture from up to 16 independent video sources
- motion, blind, night, scene change and video loss detection and event generation
- simple graphics/text overlay supporting privacy regions

Compression

- H.264 compression in Baseline Profile (BP)
- programmable resolution and frame rate
- bit rate control
 - constant
 - constant quality factor
- programmable GOP (Group of Picture)
- real-time performance including 16 D1 (720 x 480/576) or 16 CIF³ (352 x 240/288) video streams simultaneously
- interlaced encoding (D1 only)
- mono audio in G.711 A-Law format with a sampling rate of 8 kHz or 16 kHz and added to the H.264 stream¹
- H.264 stream compatible with Apple Quicktime 7⁴

I/O interfaces

- analog composite video (spot monitor) output
- 8 relay outputs
- 8 sensor inputs
- RS485/422 serial port

Host interface

- x1 PCIe™ host interface
- interrupts for start and end of frame and sequence capture
- digital video (spot monitor) output (over PCIe™)
 - any one video input
 - mosaic of any four or all sixteen video inputs
 - YUV422 pixel format

Connectors

- Two DVI for composite video input signals, for spot monitor output, and for audio inputs
- terminal blocks for I/Os and RS-485/422

Dimensions and environmental information

- MOREVOE*: 16.7 cm L x 10.7 cm H (6.6" x 4.2")⁵
- MOREVOIO*: 5.6 cm L x 10.7 cm H (2.2" x 4.2")⁵
- operating temperature: 0° C to 55° C (32° F to 131° F)
- relative humidity: up to 95% (non-condensing)
- FCC class B
- CE class B
- RoHS-compliant

Software drivers

- Matrox Imaging Library (MIL) driver for 32-bit Microsoft® Windows® XP

Ordering Information

Hardware

Part number	Description
MOREVOE*	Standard analog color/monochrome PCIe™ frame grabber for 16 video inputs and integrated H.264 video encoder.
MOREVOIO*	Add-on module for 16 I/Os and RS-485/422.

Software

Refer to MIL datasheet.

Notes:

1. Only available as part of the H.264 stream.
2. 720 x 480 resolution in NTSC and 720 x 576 resolution in PAL.
3. Common Intermediate Format (CIF) or 352 x 240 resolution in NTSC and 352 x 288 resolution in PAL.
4. Available at www.apple.com/quicktime.
5. Dimension from bottom edge of goldfinger to top edge of board.
6. Contact local representative or Matrox Imaging Sales for availability.

